

# Tru-Therm™ Industrial Sectional Doors Enquiry Form

✓ Download form to PC before editing

## Site Details

Company Name:

Date:

Delivery Address:

Customer Reference/Order Number:

Contact Name:

Phone:

Site Photos Provided:

Completed By:

## Door Requirement

[See TRU-FOLD Data Sheet for full specification details]

1. On the drawing below, enter the door opening measurements (height and width), as well as the headroom and sideroom measurements. Enter the backspace depth if applicable.

[NB: Recommended maximum door size: 5000mmH x 5600mmW. Minimum sideroom on motor side 425mm, on non-motor side 175mm. See Track Configuration table overleaf for details on minimum headroom and backspace].

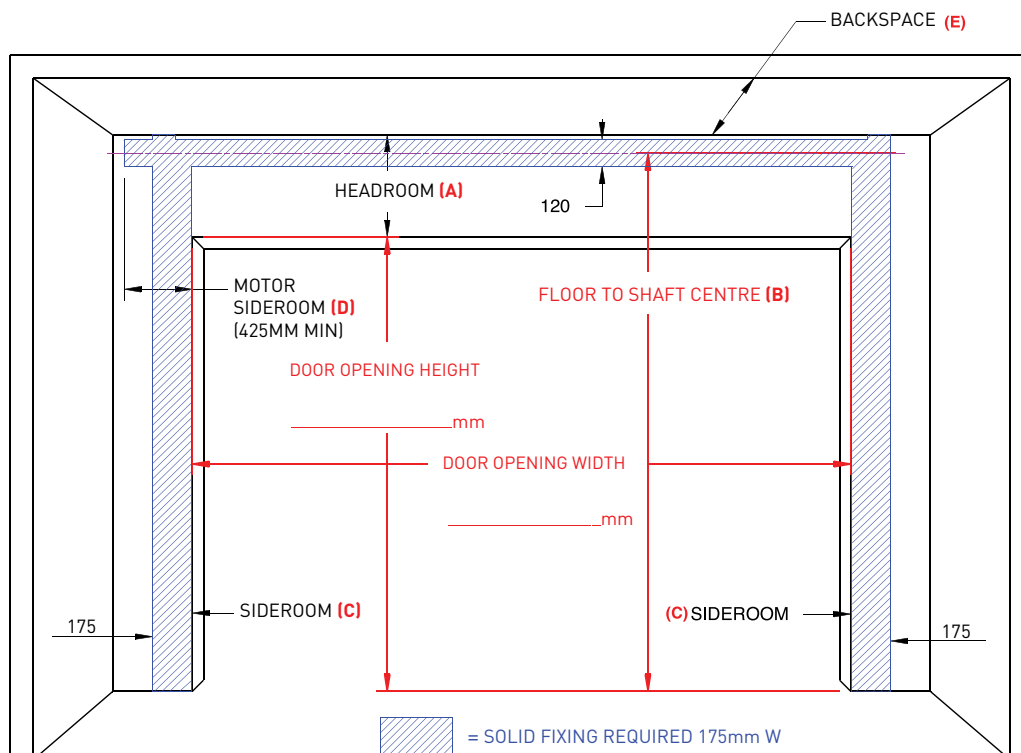

# Tru-Therm™ Industrial Sectional Doors

### 3. Operating Environment:

Temperature: °C  
Wind speed: km/h Pressure: Bar

---

### 4. Wall Construction:

Thickness: mm

---

### 5. Door Panel Options:

TRU-THERM™ Vision Panels 135mm H x 540mm W Quantity:

Optional TRU-VIEW™ fully glazed panels can be installed full -width at any position on the door. See our TRU-VIEW™ data sheet for more information.

Quantity, if required:

\*NB: TRU-THERM doors are white as standard. Options are available in standard RAL colours at extra cost, light colours only.

Special colour required RAL colour reference:

---

### 6. Door Automatic Options: (NB: Hand chain or motor must be chosen)

Manual Hand Chain

OR:

Motorised

Which Side? LH RH (Door mounting side)

---

# Tru-Therm™ Industrial Sectional Doors

## Track Configuration:

Track Option	Cable Drum	Min Headroom <b>A</b>	Amount of Lift (Top of opening to under horizontal tracks)	Floor to Shaft Centre <b>B</b>	Side Room <b>C</b>	Motor Side Room <b>D</b>	Back Space <b>E</b>
Standard Lift	4500-2 SL 5250-18 SL	4500mm Actual:	230mm	DOH + 370mm Actual:	175mm Actual:	425mm Actual:	DOH + 450mm Actual:
High Lift	5250-54 VL	up to 1625mm Actual:	<b>A</b> -250mm Actual:	DOH +LIFT +140mm Actual:	175mm Actual:	425mm Actual:	DOH -LIFT +670mm Actual:
Vertical Lift	850-11 VL 1100-18 VL	DOH + 200mm Actual:	N/A	DOH x 2 Actual	175mm Actual:	425mm Actual:	up to 600m

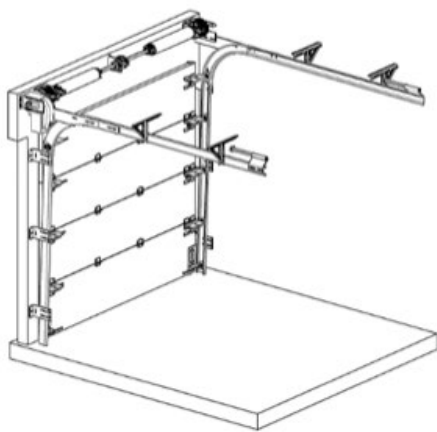

Standard Lift

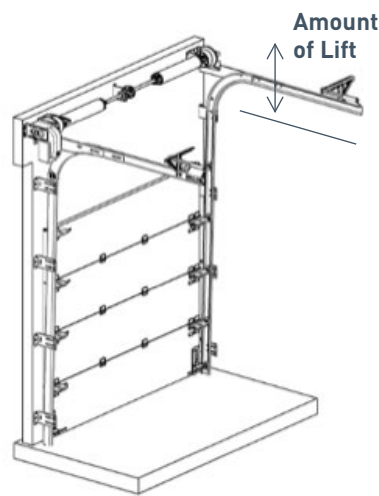

High Lift



Vertical Lift

