

TRU-THERM™ Insulated Sectional Doors

METALBILT DOORS

Designed specifically for the food-distribution industry, TRU-THERM™ doors are created to be the strongest and most reliable insulated sectional doors on the market.

TRU-THERM™ doors are easy to use and cost effective, weather-tight, air-tight and completely vermin-proof, TRU-THERM™ units are ruggedly constructed and come in a wide range of configurations and sizes to suit all conditions. High insulation ratings are guaranteed by standard 50mm overlaps, giving a very effective seal when closed, while galvanised tracks and hinges make TRU-THERM™ doors extremely corrosion resistant. TRU-THERM™ doors can be fitted with a variety of motor options and automation accessories, as well as a double seal system for use as ripening room doors.



SPECIFICATIONS

- Heavy duty 75mm Wheels and 80mm Galvanised Tracks
- 40mm polyurethane thermal break panels
- Vermin proof sealing system for increased bio-security
- Can be specified for IL4 rating against earthquakes, hurricanes and other natural disasters
- Fire resistance rating: DIN4102 Class B2
- Wind resistance rating: EN12424 Class 4
- Insulation rating: U = 0.38 Wt/mC
- Acoustic insulation decibel rating: 24dB – a perceived human volume reduction of 81.05%
- Door colour white as standard; alternative options available in 5 Colorsteel colors: Gull Grey, Sandstone Grey, Desert Sand, Cloud, and Titania. Also available in RAL 3001 Signal Red.
- Optional double-glazed vision panels
- Optional TRU-VIEW™ fully glazed panels at any position on the door

CLEARANCE DETAILS

See specific Track Configuration drawings for full clearance details.

	STANDARD LIFT	HIGH LIFT	VERTICAL LIFT
Headroom	450mm	Amount of Lift + 250mm	DOH + 200mm
Sideroom	175mm (300mm for motor)	175mm (300mm for motor)	175mm (300mm for motor)

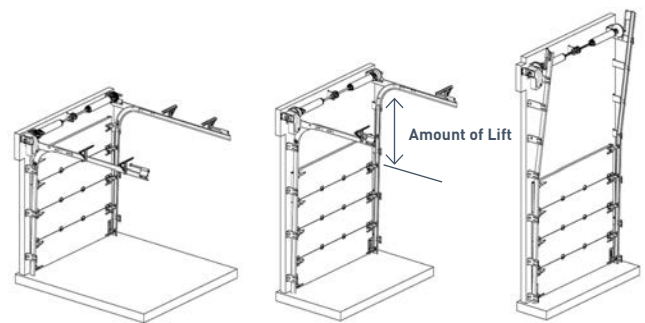

Standard Lift

High Lift

Vertical Lift

Projects

