

Tru-Therm™ Insulated Sectional Doors

Description

TRU-THERM™ Insulated Sectional Overhead Door



Product Information

Designed specifically for the food-distribution industry, TRU-THERM™ doors are created to be the strongest and most reliable insulated sectional doors on the market. TRU-THERM™ doors are easy to use and cost effective, weather-tight, air-tight and completely vermin-proof, TRU-THERM™ units are ruggedly constructed and come in a wide range of configurations and sizes to suit all conditions. High insulation ratings are guaranteed by standard 50mm overlaps, giving a very effective seal when closed, while galvanised tracks and hinges make TRU-THERM™ doors extremely corrosion resistant. TRU-THERM™ doors can be fitted with a variety of motor options and automation accessories, as well as a double seal system for use as ripening room doors.

Technical Specification

- Max Size: 5000mmH x 5600mmW
- Heavy duty 75mm Wheels and 80mm Galvanised Tracks
- 40mm polyurethane thermal break panels
- Vermin proof sealing system for increased bio-security
- Can be specified for IL4 rating against earthquakes, hurricanes and other natural disasters
- Fire resistance rating: DIN4102 Class B2
- Wind resistance rating: EN12424 Class 4
- Insulation rating: U = 0.38 Wt/mC
- Acoustic insulation decibel rating: 24dB – a perceived human volume reduction of 81.05%
- Door colour white as standard; alternative options available in 5 Colorsteel colors: Gull Grey, Sandstone Grey, Desert Sand, Cloud, and Titania: <https://www.colorsteel.co.nz/colours/#colour-palette> - Also available in RAL 3001 Signal Red.
- Optional double-glazed vision panels
- Optional TRU-VIEW™ fully glazed panels at any position on the door

Clearance Details:

See specific Track Configuration drawings for full clearance details.

	Standard Lift	High Lift	Vertical Lift
Headroom	450mm	Amount of Lift + 250mm	DOH + 200mm
Sideroom	175mm (300mm for motor)	175mm (300mm for motor)	175mm (300mm for motor)

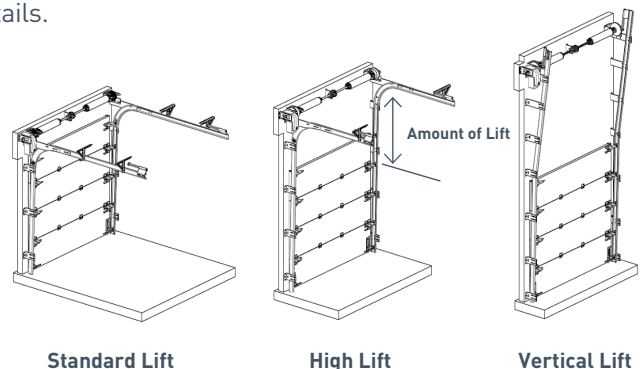

TRU-THERM™ Projects



Banana Rooms

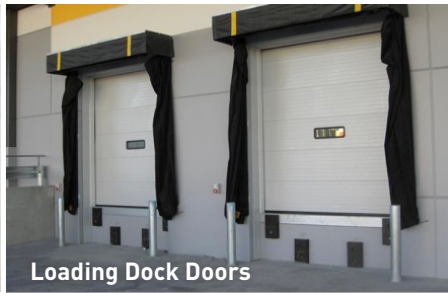

Loading Dock Doors



Vertical Lift



High Lift



Standard Lift

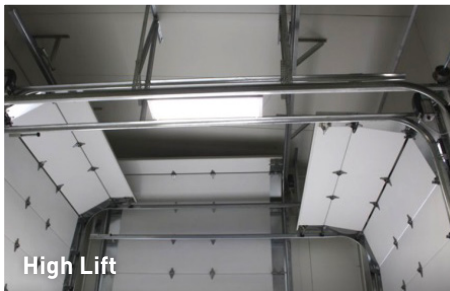

High Lift

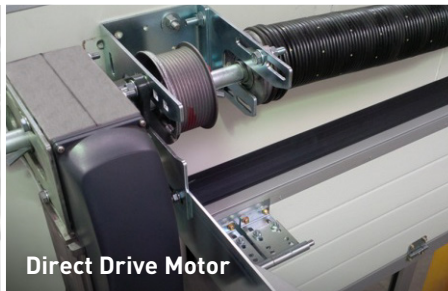

Direct Drive Motor



Drive Shaft with Bearings

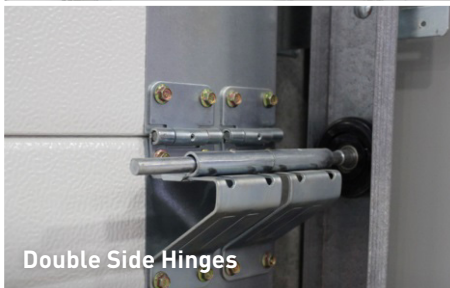

Double Side Hinges

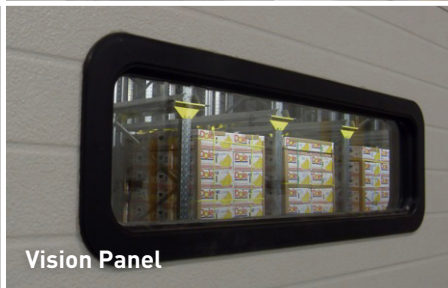

Vision Panel



Bottom Seal